

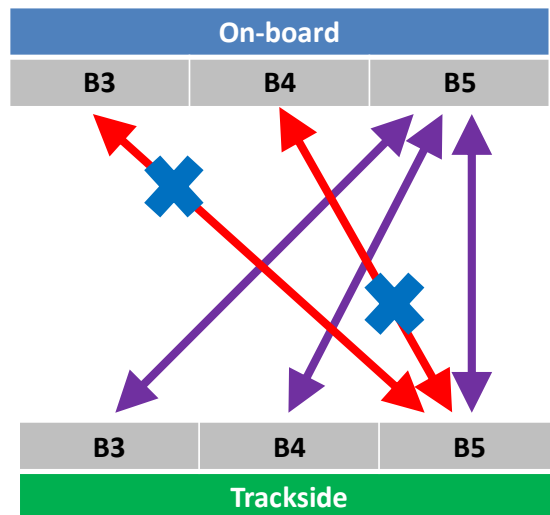

# ERTMS and Compatibility



This report is written for:  
**ERTMS World Conference 2016**

By:  
**Dr.ir. L. (Lieuwe) Zigterman**

© **DoorZigt B.V.**

Filename: ERTMS and Compatibility

Date: 28-1-2016

DoorZigt B.V.  
Groenesteeg 37d  
2312 TK LEIDEN  
The Netherlands  
Reg. N° 0810.8843

DoorZigt B.V. – Éire  
c/o Lieuwe Zigterman  
Inis Meáin, Oileáin Árann  
Co. na Gaillimhe  
Reg. N° 907430

telephone NL +31 6 5148 5690  
telephone IRL +353 87 337 1656  
e-mail LZ@DoorZigt.EU  
web www.doorzigt.eu  
VAT NL8110.76.520 B.01

## Summary

For speeding up the implementation of ERTMS in Europe, the European ERTMS Coordinator, Karel Vinck, developed in his Work Plan a *breakthrough program*. This program is based on a number of principles, of which the first is: “*Users first*” and not “*Designers first*”. In his approach the *Users* are the Railway Undertakings as these are in a competitive situation, whereas the Infrastructure Managers have a national monopoly.

In this context it does not seem the best choice to let these Railway Undertakings implement Baseline 3 of ERTMS first, before Infrastructure Managers can implement the new functionalities of this Baseline on any of the lines belonging to their network. Nevertheless, this is the current approach as laid down in the ERTMS specifications, i.e. in the System Requirements Specification (SRS) and further elaborated upon in the SUBSET-104 which is dedicated to the subject of migration.

The current approach leads to RUs being forced to implement the newest features each and every time a new system version is defined, whereas Infrastructure Managers can choose to implement any of these features or not. In this context it is to be noted that the European fleet of rolling stock is only partly operating on a European scale, while a much larger portion of this fleet is limited to domestic operations.

In the process of upgrading, the current approach also leads to strict interdependencies between Infrastructure Managers and Railway Undertakings. So, although according to this approach the *Users* are indeed the *first* implementers, this does not comply with the intentions of Karel Vinck: “*Users first*”.

As another approach seems to fit better with (or: is even a condition sine qua non for) the *breakthrough program* of Karel Vinck, in close cooperation between Walenberg Rail Assessment (WRA) and DoorZigt B.V. the concept of *symmetrical compatibility* is developed. The *symmetrical compatibility* implies that both sides (on-board and trackside) are specified and designed in such a way that in both directions as well backward as forward compatibility is provided. As a consequence, either trackside can be upgraded first or on-board can be upgraded first. The Infrastructure Manager and Railway Undertaking can also decide to leave existing implementations (trackside respectively on-board) unaltered. This is of utmost importance for the domestic fleets of rolling stock, which do not require new features, which might be needed at the European level.

The *symmetric compatibility* supports a smooth adaptation of new system versions, i.e. of new functionalities as well as system improvements in terms of fault repairs. In this way, *symmetric compatibility* creates realistic conditions for a *breakthrough* for the further roll-out of ERTMS all over the European railway networks as well as in the European railway fleet.



## Table of Contents

Summary .....	2
Table of Contents .....	3
1. Introduction.....	4
1.1. Purpose of this document.....	4
1.2. Structure of the document .....	4
2. References and terminology.....	5
2.1. References.....	5
2.2. Abbreviations .....	6
3. Compatibility.....	7
3.1. Backward compatibility.....	7
3.2. Forward compatibility .....	7
3.3. Symmetric compatibility.....	8
3.4. Asymmetric compatibility.....	9
4. Background: European context .....	10
4.1. MoU 2012.....	10
4.2. RISC DV73.....	10
4.3. Work Plan Karel Vinck.....	10
4.4. European fleet of rolling stock .....	11
5. Compatibility as foreseen .....	11
6. Issues related to compatibility .....	12
6.1. Main implication.....	12
6.2. Migration: SUBSET-104 .....	12
6.3. Summary.....	14
7. Proposal for Symmetrical compatibility.....	14
8. Implications of symmetrical compatibility.....	15
9. Conclusions.....	16
10. Annex A: terminology.....	17
10.1. Baselines and System Versions .....	17
10.2. Document versions .....	17
10.3. Relationships .....	17
10.4. Comments .....	18
11. Annex B: RBC-RBC communication.....	18

## 1. Introduction

This document is prepared in the context of the ERTMS World Conference 2016 for which DoorZigt B.V. is invited to prepare a poster session.

### 1.1. *Purpose of this document*

DoorZigt B.V. considers it beneficial not only for Railway Undertakings, but also for Infrastructure Managers, if ETCS would be designed in such a way that compatibility between System Versions becomes *symmetrical*. This means that – between reasonable limitations – rolling stock equipped with whatever System Version should be able to run on infrastructure with whatever System Version. And, in addition, that both sides, i.e. IM and RU can choose upgrading to newer System Versions in their own pace, without tight intertwinement of time schedules.

This document provides for a summary of the backgrounds and the motivation for choosing *symmetrical compatibility*.

### 1.2. *Structure of the document*

After the introductory chapters 1 and 2, the term *compatibility* in a generic sense is discussed in chapter 3. In chapter 4 the actual European context is investigated. Chapter 5 presents the presently foreseen compatibility, while chapter 6 analyses its implications, specifically with respect to backward compatibility issues and migration. From these issues, emerges the basic idea of *symmetric compatibility*, which is presented in chapter 7. Chapter 8 provides for an outline of the implications of the symmetric compatibility, as well for Railway Undertakings as for Infrastructure Managers. Conclusions are given in the final chapter 9.

The *Annex A: terminology* provides for clarifications concerning the terms Baseline, System Version and related document versions as used in the ERTMS community. Finally *Annex B: RBC-RBC communication* provides for information on the *symmetric compatibility* as is already defined for the communication between neighbouring RBCs with different system versions.

## 2. References and terminology

### 2.1. References

#### European legislation

The following formal documents apply:

- [1] Directive 2008/57/EC of 17 June 2008 on the interoperability of the rail system within the Community – Official Journal of the European Union L 191/1 of 18.7.2008; the Interoperability directive, as amended by:
  - a. Directive 2009/131/EC of 16 October 2009 amending Annex VII to Directive 2008/57/EC of the European Parliament and of the Council on the interoperability of the rail system within the Community – Official Journal of the European Union L 273/12 of 17.10.2009.
  - b. Directive 2011/18/EU of 1 March 2011 amending Annexes II, V and VI to Directive 2008/57/EC of the European Parliament and of the Council on the interoperability of the rail system within the Community – Official Journal of the European Union L 57/21 of 2.3.2011.
- [2] COMMISSION DECISION 2012/88/EU of 25 January 2012 on the technical specification for interoperability relating to the control-command and signalling subsystems of the trans-European rail system.
- [3] COMMISSION DECISION 2012/696/EU of 6 November 2012 amending Decision 2012/88/EU on the technical specifications for interoperability relating to the control-command and signalling subsystems of the trans-European rail system.
- [4] COMMISSION DECISION (EU) 2015/14 of 5 January 2015 amending Decision 2012/88/EU on the technical specification for interoperability relating to the control-command and signalling subsystems of the trans-European rail system (notified under document C(2014) 9909)

#### European level

- [5] Memorandum of Understanding (MoU) between the European Commission, the European Railway Agency and the European Rail sector Associations (CER – UIC – UIFE – EIM – GSM-R Industry Group – ERFA) concerning the strengthening of cooperation for the management of ERTMS, Copenhagen, April 2012.
- [6] Management of ERTMS specifications in the context of an ERTMS breakthrough program – Working document RISC, 08/57-DV73 Version EN01 of 27.05.2014
- [7] ERTMS Work Plan of the European Coordinator of December 2014

#### SUBSETs

The following documents concerning System Versions are specifically addressed in this document:

- [8] ETCS System Version Management, SUBSET-104, issue 3.2.0, date 12-05-2014, published by ERA
- [9] FIS for the RBC / RBC handover, issue 3.1.0, date 09-05-2014, published by UNISIG



## Baseline Compatibility Assessment

The following documents concerning the Compatibility Assessment are specifically addressed in this document:

[10] Baseline Compatibility Assessment – Final Report, reference EUG\_UNISIG\_BCA, issue 1.0.0, date 22-05-2014

[11] Hazard Items for Baseline Compatibility Assessment, SUBSET-128, issue 1.0.0, date 22-05-2014.

### **2.2. Abbreviations**

In this document the following abbreviations are used:

<b>Abbreviation</b>	<b>Meaning</b>
BCA	Baseline Compatibility Assessment [10]
CCS	Control, Command & Signalling
CR	Change Request
ERA	European Railway Agency
ERTMS	European Rail Transport Management System
ETCS	European Train Control System
EU	European Union
EUG	ERTMS Users Group
IM	Infrastructure Manager
RBC	Radio Block Centre
RU	Railway Undertaking (or: Train Operating Company)
SV	System Version (of ETCS)
TSI	Technical Specification for Interoperability
UNISIG	Industrial consortium of ERTMS/ETCS Suppliers

### 3. Compatibility

This chapter outlines in short the following four labels for compatibility, i.e.:

- Backward compatibility.
- Forward compatibility
- Symmetric compatibility.
- Asymmetric compatibility.

For ease of reference to the ERTMS application the on-board and trackside are used in the examples presented here.

#### 3.1. *Backward compatibility*

In Figure 1 an example is shown of an on-board equipped with the (higher) software version B5, which is compatible with a track-side based on the same software version B5, as well as an older software version B4 as well as an earlier software version B3. So, the on-board B5 is *backward compatible* with these earlier software versions B3 and B4.

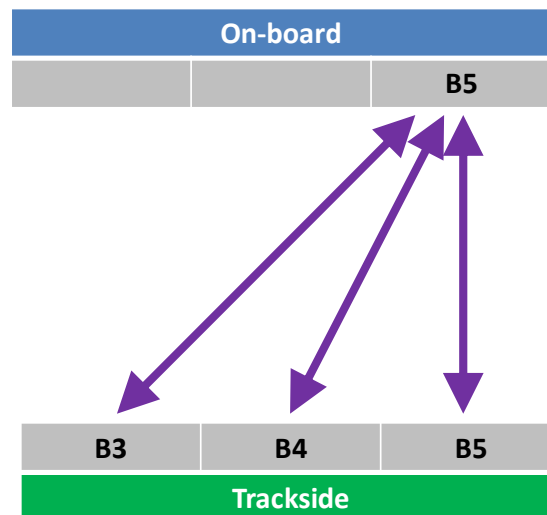

Figure 1 Example of backward compatibility

*Note: in the example the on-board is backwards compatible with the trackside. But on-board and trackside may also be interchanged, so that the trackside B5 becomes backwards compatible with on-board B3 and B4.*

#### 3.2. *Forward compatibility*

In Figure 2 an example is shown of an on-board equipped with the (lower) software version B3, which is compatible with a track-side based on the same software version B3, as well as a newer software version B4 as well as the newest software version B5. So, the on-board B3 is *forward compatible* with these newer software versions B4 and B5.

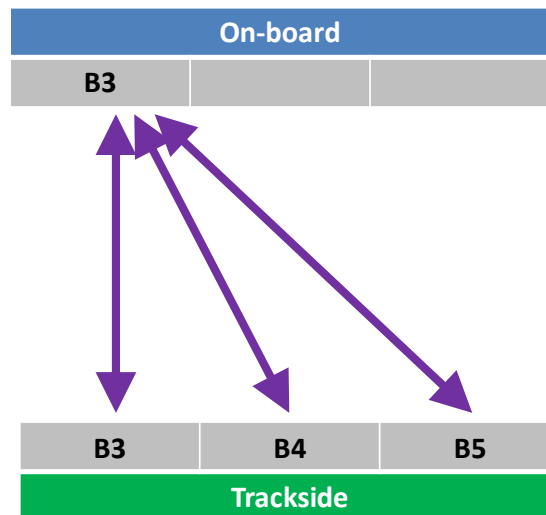

Figure 2 Example of forward compatibility

*Note: in the example the on-board is forwards compatible with the trackside. But on-board and trackside may also be interchanged, so that the trackside B3 becomes forward compatible with on-board B4 and B5.*

### 3.3. Symmetric compatibility

In Figure 3 an example is shown of an on-board equipped with either software version B3, B4 or B5 which is compatible with a track-side based on any of these software versions B3, B4 or B5. In both directions as well backward as forward compatibility is provided. So, an example of full *symmetric compatibility* between any of the three software versions.

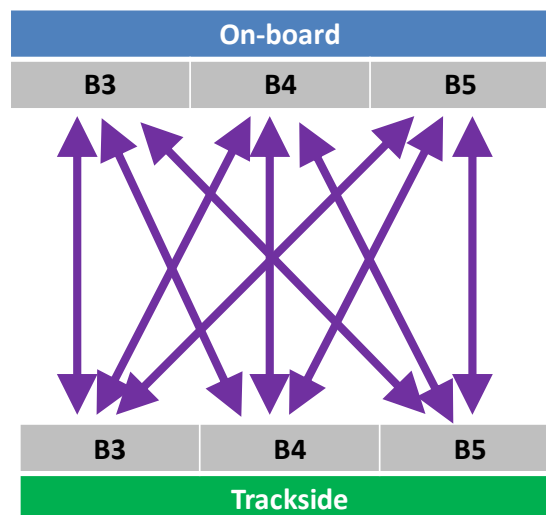

Figure 3 Example of symmetric compatibility

*Note: in practice the on-board and trackside will choose for one version to communicate in: either B3 is used at both sides, or B4 or B5. This is depicted in Figure 3 by the vertical arrows. See also Figure 7 on page 14.*



### 3.4. Asymmetric compatibility

In Figure 4 an example is shown of an on-board equipped with the (latest) software version B5, which is compatible with a track-side based on the same software version B5, as well as an older software version B4 as well as an earlier software version B3. So, the on-board B3 is *backward compatible* with these earlier software versions B3 and B4.

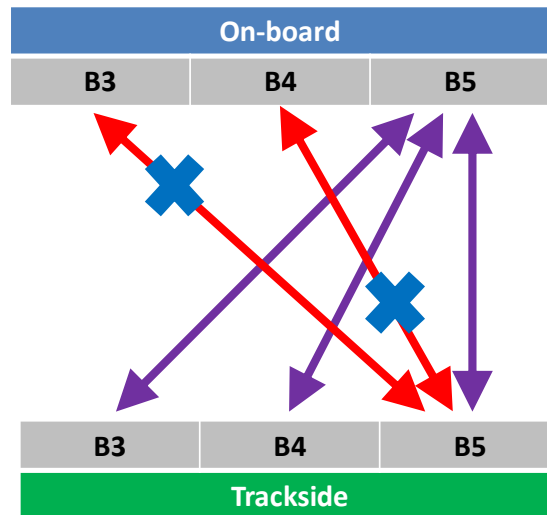

Figure 4 Example of asymmetrical compatibility

But, an on-board equipped with an earlier software version B3 or B4 is not able to run on a trackside equipped with the newest software version B5.

So this compatibility can be labelled as *asymmetrical compatibility*: only in one direction (from on-board to trackside) backward compatibility is provided.

**This *asymmetrical compatibility* is the compatibility as defined in the present Baseline 3 documents.**

## 4. Background: European context

This chapter provides for an outline of the European background for the development of the proposal for *symmetric compatibility*.

The following sources are used in this chapter:

- Memorandum of Understanding of 2012 [5].
- RISC document DV73: Management of ERTMS specifications in the context of an ERTMS breakthrough program [6].
- ERTMS Work Plan of December 2014 of the European coordinator [7].

The chapter is concluded with considerations on the European fleet of rolling stock.

### 4.1. MoU 2012

In this context one should take notice of the MoU [5], specifically clause (36):  
“...ensuring that backward and, wherever technically possible, forward compatibility is secured.”

As the MoU only uses “backward compatibility” and “forward compatibility” and is not explicit on compatibility issues between trackside and on-board, it follows that the MoU is not clear in its intentions.

### 4.2. RISC DV73

In the document DV73 [6] we first of all read:

“There will be a continues need for changes/versions...”

And further on:

“backward compatibility and forward compatibility with baseline 3 are the target”

Also this document is not explicit on the relationship between on-board and trackside with respect to the compatibility issue, although it is clearer about the target: as well *backward as forward* compatibility.

### 4.3. Work Plan Karel Vinck

In his Work Plan December 2014 [7] the European ERTMS Coordinator Karel Vinck is clearer about the direction of the compatibility: from on-board towards trackside, which follows from the following citations:

Baseline 3 compliant on-board “should be able to run everywhere in Europe”

“Baseline 3 (train) can run on Baseline 2 trackside”

Further elements from this Work Plan which are of utmost relevance in the present context are the following:

Karel Vinck speaks about a “breakthrough program”

Of which the first principle is: “*Users first*” and not “*Designers first*”.

And: the “*Users*” are the Railway Undertakings (RUs).

This first principle is also the starting point for the proposal, which is presented hereafter.

#### 4.4. European fleet of rolling stock

The nowadays valid TSI-CCS [2] as amended by [4] has a wide scope of validity. Practically it requires the whole European fleet of rolling stock to be equipped with ERTMS, whether the rolling stock will run across borders or only provide for domestic services.

In our estimate less than 10% of the European fleet of rolling stock units is operating cross-border and more than 90% only provides for domestic services. But the TSI-CCS applies to both parts of the fleet of rolling stock.

### 5. Compatibility as foreseen

UNISIG prepared an interesting figure to visualise the compatibility as foreseen between Baselines and System Versions. This visualisation is copied here as Figure 5.

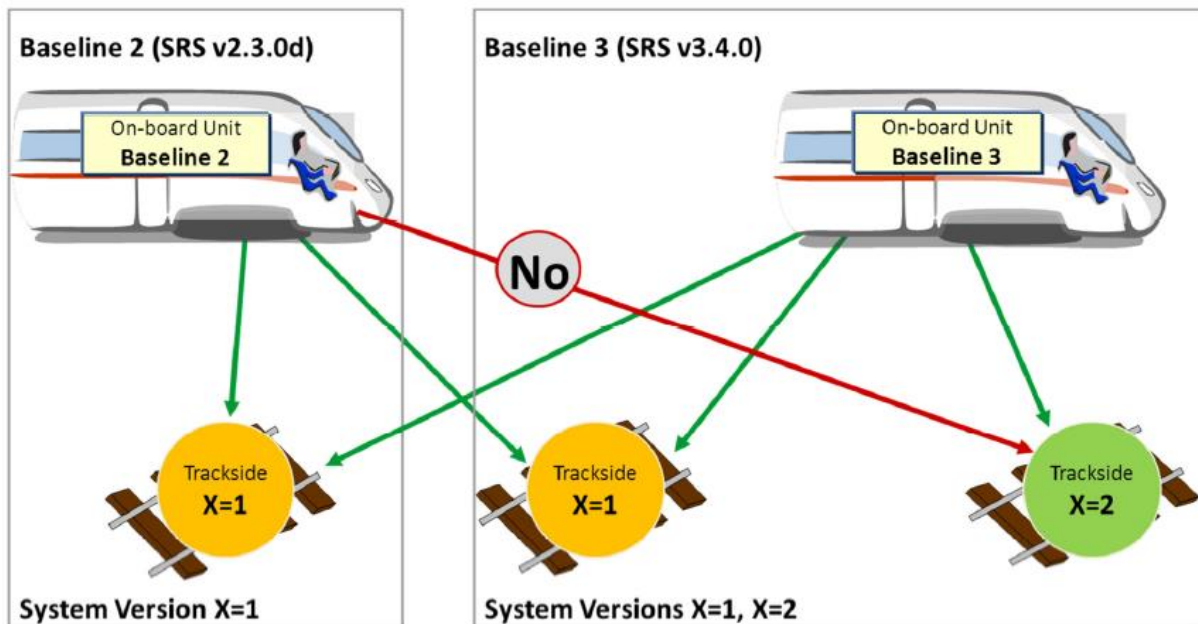

Figure 5 Compatibility as presented in BCA Report 2.2.1.5 page 9 [10]

As visualised in this figure there is only backward compatibility (compare 3.1) of on-board with respect to the trackside, not the other way around. So: compatibility as currently defined is *asymmetrical* (compare Figure 4 in 3.4).

## 6. Issues related to compatibility

This chapter discusses the main implication of the asymmetrical compatibility (6.1) and the foreseen process for migration (6.2) and is concluded with a short summary (6.3).

### 6.1. Main implication

The first and main implication of the asymmetrical compatibility is the consequence that the on-board is always to be upgraded first, before any trackside implementation can opt for a new software version. Taking notice of DV73 “There will be a continuous need for changes/versions...” (compare 4.2), this implies that RUs are forced to follow each and every upgrade in ERTMS specifications.

### 6.2. Migration: SUBSET-104

For the process of migration ERA published SUBSET-104 on ETCS System Version Management [8]. In SUBSET-104 a number of examples concerning the evolution of ERTMS System Versions are presented.

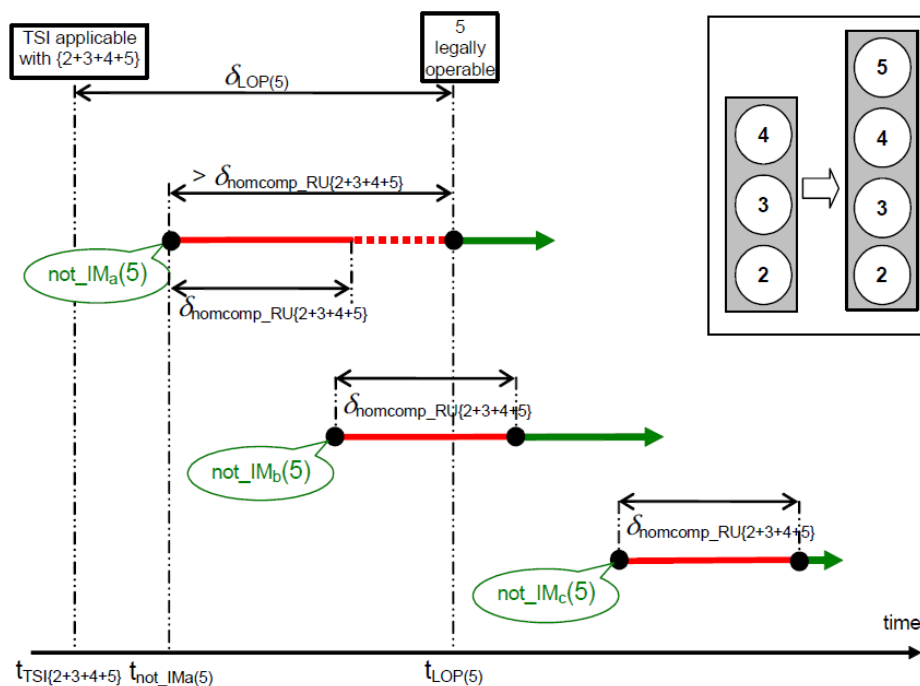

Figure 17: creation of new X version, with no phasing out

#### Figure 6 Example of introduction of new System Version X (copied from SUBSET-104 [8])

The one example which is of relevance now (i.e. from Baseline 2 with only one System Version, to Baseline 3 with two / three<sup>1</sup> System Versions) is the case of the introduction of a new System Version, i.e. “Model 1” in SUBSET-104.

<sup>1</sup> In ERTMS terminology the 1.1 is a *compatible* System Version and 1.y and 2.y are labelled as *incompatible* System Versions. As a consequence, only **two** versions are counted in the context of migration in the formal sense. But if one likes to count 1.1 as a separate version (as it provides specific interesting functionalities), then there are **three** System Versions.



The time line for introducing a new System Version is shown in Figure 17 of SUBSET-104, which is copied here in Figure 6 (see preceding page): Version X=5 is added to the “envelope” of 2+3+4. So the envelope is extended from three to four System Versions X.

The meaning of the parameters which are used in this figure is shown in Table 6-1:

Symbol	Meaning
$t_{TSI(2+3+4+5)}$	New TSI applicable, which defines new System Version 5 (and maintains 2, 3 and 4)
$\delta_{LOP(5)}$	Initial transition period for the first preparation of the products; only after this period, the new X=5 version becomes legally operable
$not\_IM_n(5)$	$IM_n$ notifies its intention to aim at operating the new X=5 version
$\delta_{nomcomp\_RU}$	Unique nominal value for compliance period, in which RU shall fit its fleet with ETCS on-board supporting the new envelope of versions 2+3+4+5

**Table 6-1 Meaning of symbols used in Figure 17 of SUBSET-104**

As can be deduced from Figure 6 and Table 6-1 there is a minimum period foreseen in which RUs (and IMs as well as the suppliers) can prepare for the implementation of the new System Version 5 ( $\delta_{LOP(5)}$ ; indicative value<sup>2</sup>: >2 years). Then each IM has to notify its intentions to implement the new System Version 5 ( $not\_IM_n(5)$ ) and allow for another minimum period the RUs operating on the infrastructure concerned for the implementation of the new System Version 5 ( $\delta_{nomcomp\_RU}$ ; indicative value: 2 years) in the fleet involved. At this moment no actual figures for the introduction of System Version 2.0 (which is defined in Baseline 3) have been defined.

One has to take account of the fact that any RU which is operating internationally, has to deal with a number of Infrastructure Managers, each of which may decide in its own to implement the new System Version or not (yet). The IM can choose different versions per trajectory (and, in addition, different ETCS Levels). Of course, the first IM notifying will determine the moment for the RU concerned to implement the new System Version in its fleet. But, this new System Version might:

- Provide for new functionalities in which the RU itself is not interested at all.
- And / or:
- Use the new functionalities only on a small part of the trajectory (of the first IM implementing) on which the fleet of the RU is operating.

<sup>2</sup> According to Annex B, 8.2.2 of SUBSET-104.

### 6.3. Summary

The preceding outline is summarised as follows:

1. The asymmetrical compatibility leads to strict interdependencies for upgrading infrastructure in relation to rolling stock which is using this infrastructure.
2. Specifically in an international perspective (for which ETCS is primarily defined) the migration by the different involved Infrastructure Managers and Railway Undertakings requires long-term-planning agreements and strict coordination.
3. If the preceding condition is not met, RUs may be forced to invest in a new System Version, which only will be used in a limited sense, e.g. only on a part of the network of one IM.

## 7. Proposal for Symmetrical compatibility

A proposal is developed to allow for an on-board with any System Version to run on any trackside, i.e. the trackside shall be able to communicate with any<sup>3</sup> on-board System Version. In other words: *symmetrical compatibility*. DoorZigt B.V. defined the *symmetric compatibility* in further detail, including an overview of the changes which are to be implemented in the ERTMS SRS Baseline 3 to define this alternative approach to compatibility. These changes in the SRS prove to be very limited.

This concept of *symmetrical compatibility* is visualised in Figure 3 in 3.3. In practice (for the current System Versions defined in Baseline 3) the on-board and trackside will communicate as visualised in Figure 7.

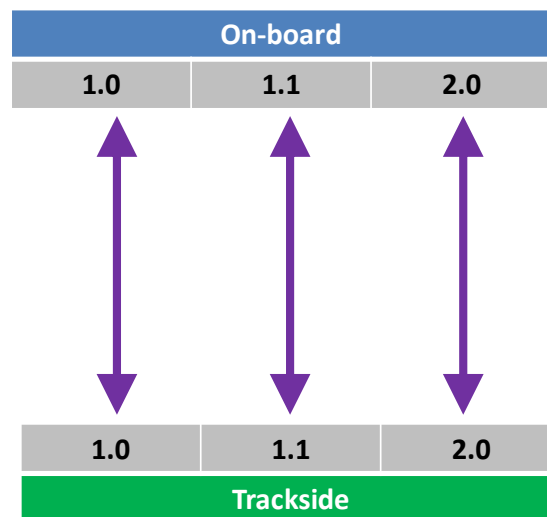

Figure 7 Symmetric compatibility practically

During the initialisation phase of communication between on-board and trackside (in a similar way as the current ERTMS specifications prescribe), the on-board and

<sup>3</sup> “Any” means – in line with the SRS, specifically chapter 6, and SUBSET-104 [8] – the “envelope of legally operated system versions”.



trackside will agree upon the System Version in which they will further exchange information: either in line with the definitions of:

- System Version 1.0,
  - System Version 1.1,
- Or:
- System Version 2.0.
- (i.e. the three System Versions which are defined in the Baseline 3).

So only one of the three arrows depicted in Figure 7 will be active for a specific on-board communicating with the trackside.

In the concept of symmetric compatibility it is foreseen that at one and the same moment a trackside RBC may communicate with one train in accordance with SV 1.1 and with another train in its area in accordance with SV 2.0 (as an example).

In the most extreme situation (within the current Baseline 3 definitions), the RBC may communicate:

- With one train (or: more trains) in accordance with SV 1.0,
  - With another train (or: other trains) in accordance with SV 1.1
- And:
- With a third train (or: more trains) in accordance with SV 2.0.

## 8. Implications of symmetrical compatibility

Concerning upgrading and migration, the *symmetric compatibility* implies:

- Trackside can upgrade independently of rolling stock; in other words:
  - IM is independent of RUs.
- On-board can upgrade independently of trackside(s); in other words:
  - RU is independent of IMs.

Of course:

- From an economical point of view some level of coordination between the concerned RUs and IMs is reasonable in order to agree on which System Version(s) and / or which functions must be supported by both sides.

Another important implication of the *symmetric compatibility* is:

- Neither trackside is required to implement all System Versions.
- Nor on-board is required to implement all System Versions.

This principle can be applied under the following condition:

- Trackside and on-board must have one match, i.e. one System Version which both sides support.



## 9. Conclusions

The proposal for symmetric compatibility can be summarised as follows:

1. A balanced treatment of on-board and trackside is its main feature.
2. By definition, the *symmetric compatibility* allows for migration of on-board fully independent of migration of track-side, albeit that some level of coordination between RUs and IMs concerned is reasonable from an economical point of view.
3. The *symmetric compatibility* provides for a realistic way-out for speeding up deployment of ERTMS by really implementing the “*Users first*” principle of Karel Vinck.



## 10. Annex A: terminology

The terminology used in the ERTMS context might be confusing, as strongly related terms are used in a specific definition for ERTMS; i.e.:

- Baseline
- System Version
- Document versions

In addition: there are no clear 1-to-1 relationships. Hereafter these terms are clarified.

### 10.1. **Baselines and System Versions**

At this stage of development of ERTMS there are two baselines, labelled as Baseline 2 (B2) and Baseline 3 (B3). There are three System Versions distinguished, i.e.:

- System Version 1.0
- System Version 1.1
- System Version 2.0

According to the terminology used, 1.1 is compatible with 1.0, but 1.x and 2.0 are incompatible System Versions.

System Versions define the messages, the packets and the variables which are used for the communication over the air gap, i.e. between trackside and on-board. Each of these three building blocks of the ERTMS language are defined with (slightly) different meanings in each System Version.

### 10.2. **Document versions**

The most important versions of the SRS, i.e. SUBSET-026 (there have been many more versions published at some stage of the ERTMS evolution) are the following versions:

- 2.3.0
- 3.0.0 (first B3 release)
- 3.4.0 (published with TSI 2015/14/EU) – actual valid version
- 3.5.0 is (was) foreseen by end of 2015
- (and 3.6.0 will presumably follow)

*Note: there is no SUBSET-026 in version 2.3.0d; this label defines a combination of specifications, specifically of the SRS = SUBSET-026 version 2.3.0 plus SUBSET-108, which provides an overview of Chang Requests and their status.*

### 10.3. **Relationships**

The following relationships apply:

- Baseline 2 = 2.3.0d, which defines:
  - SV1.0
- Baseline 3 = SRS 3.x.0, which defines:
  - SV1.0
  - SV1.1
  - SV2.0

### 10.4. Comments

The following comments apply to these relationships and definitions:

1. B2 (2.3.0d) SV1.0 differs from B3 SV1.0.
2. B3 definitions are still evolving (as indicated in 10.2 by the different versions 3.x.0).

## 11. Annex B: RBC-RBC communication

UNISIG foresees for the RBC-RBC communication in the SUBSET-039 [9] in chapter 6 “Management of older system versions” the possibility for RBCs which are implemented in accordance with different System Versions, to communicate. This is visualised in figure 6 of the SUBSET, which is copied here as Figure 8.

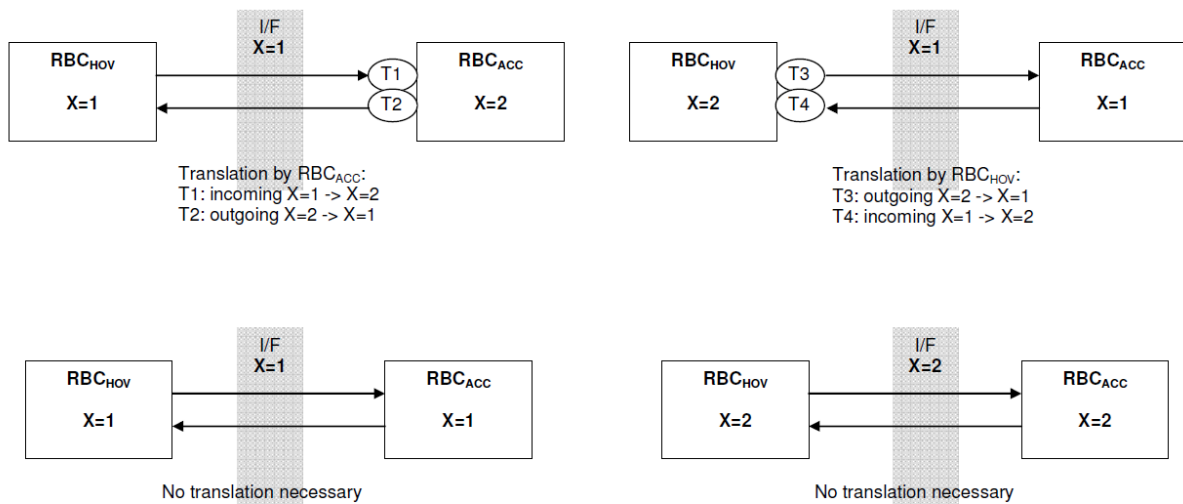

Figure 6: Interfacing RBCs with different system versions X

Figure 8 RBC/RBC communication in symmetric way [9]

From this we conclude that also UNISIG considers the concept of *symmetric compatibility* as a technically feasible solution.